

# TYPE A

## Ref.: 156209



ISO/PAS 11154



CITY CRASH TEST



### n° 209



**Citroen Berlingo**  
**Citroen Xsara Picasso**  
**Peugeot Partner / Ranch**

5

07/1996->06/2008

5

12/1999->

5

06/1996->12/2007

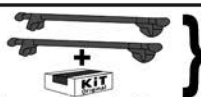

**5 kg + xx Kg = 75 kg max**

Ne pas dépasser la charge maximale des barres. Ne pas dépasser la charge maximale indiquée par le constructeur du véhicule

Non superare il carico massimo delle barre portatutto. Non superare il carico massimo indicato dal costruttore del veicolo

Carga máxima admisible indicada en la caja de las barras de techo. No exceda la carga máxima permitida por el fabricante del vehículo.

Maximum allowable load indicated on the box of roof bars. Do not exceed the maximum load allowed by the vehicle manufacturer.

Maximal zulässige belastung angegeben auf der box der dachreling. Überschreiten sie nicht die maximale belastung durch den fahrzeughersteller zugelassen.

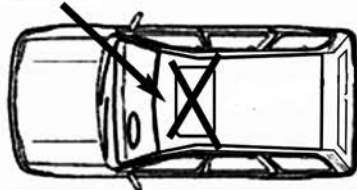
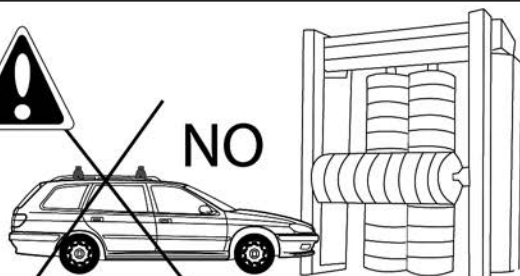
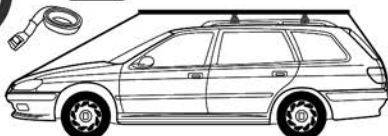



M6x50



x4

162100001

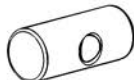

x4

6591.06



x4

100005

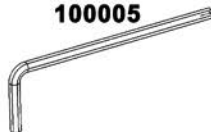

x1



x1  
1120901



x1  
1120902



x1  
1120903



x1  
1120904



x2  
209AB



x2  
209CD

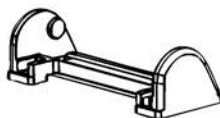

x4  
81018

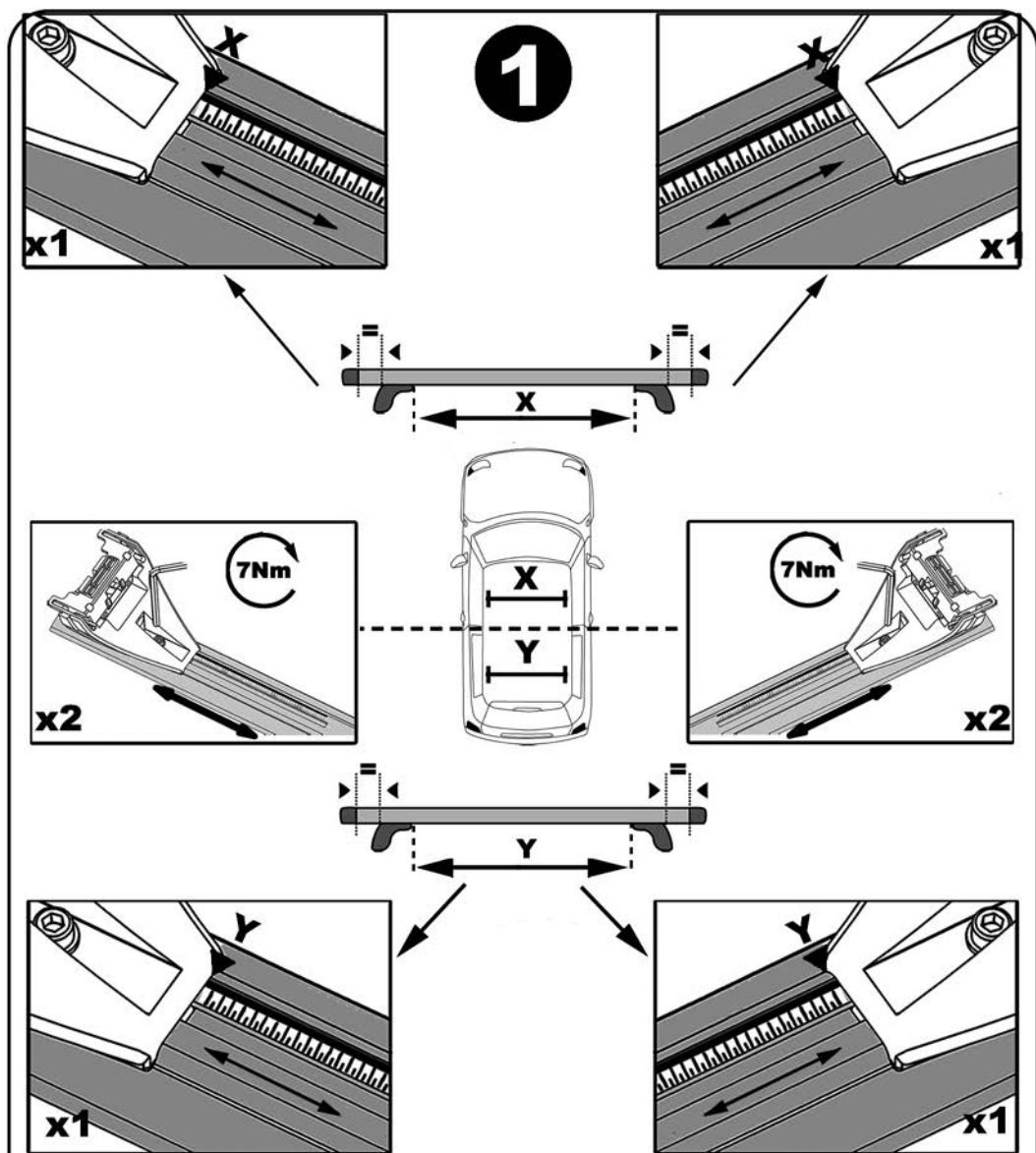

	X	Y
Xsara Picasso	78,5 cm	77,5 cm
Berlingo	81,5 cm	82 cm
Partner / Ranch	81,5 cm	82 cm

Citroen Xsara Picasso

Citroen Xsara Picasso

**2**

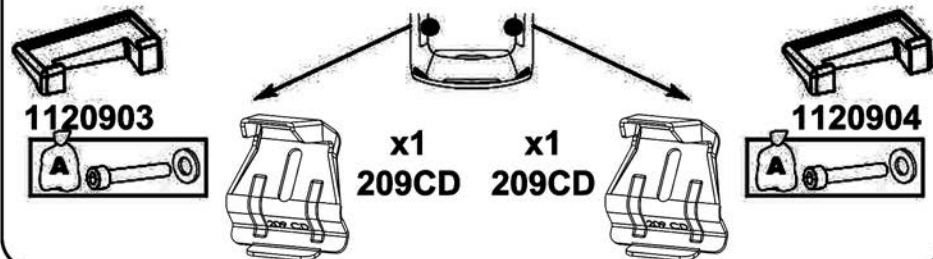
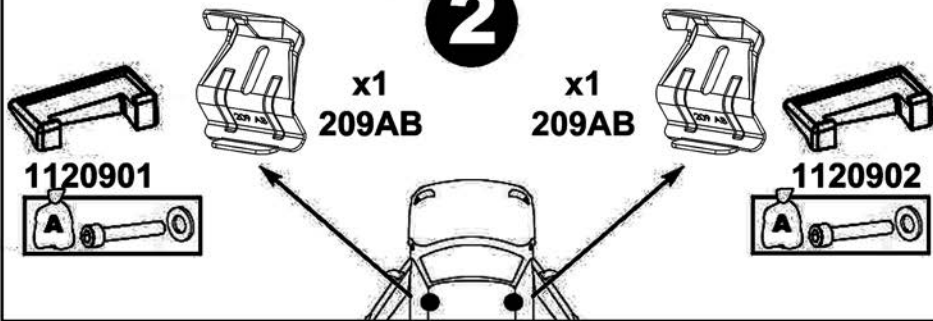

Citroen Berlingo - Peugeot Partner / Ranch

**2**

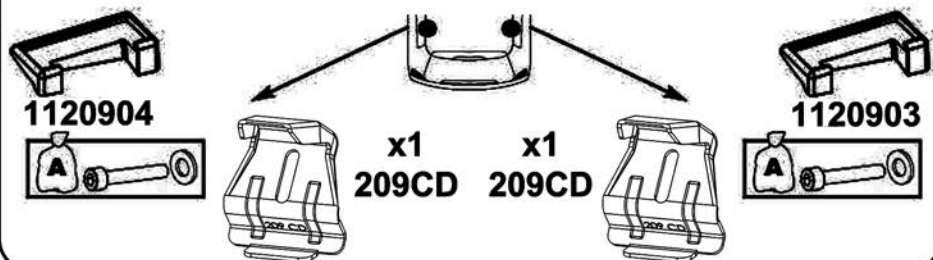
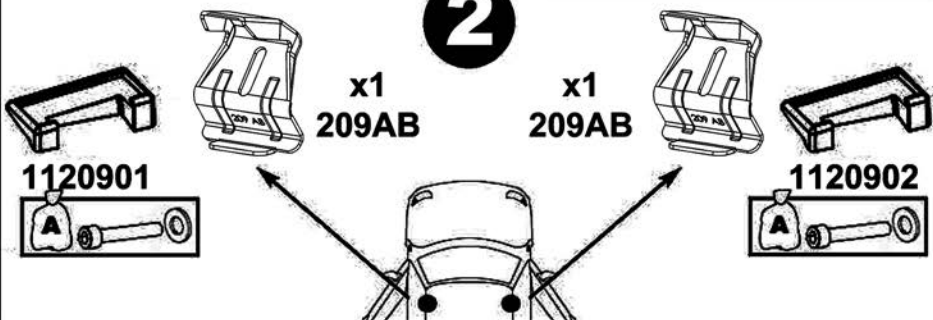

**5**

**x4**

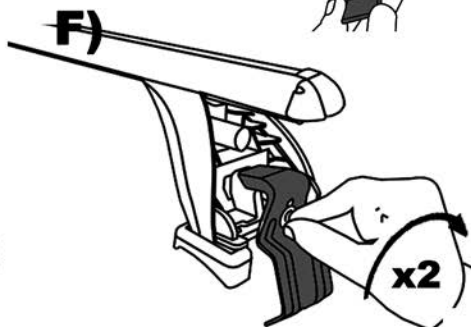
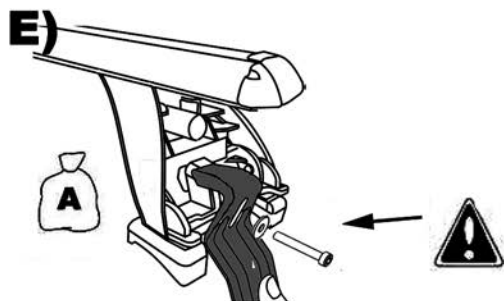
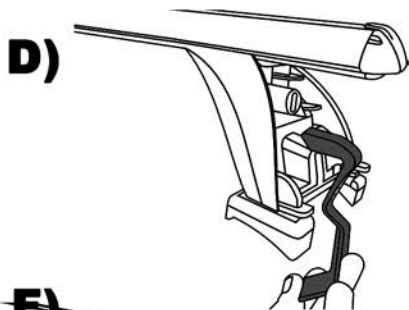
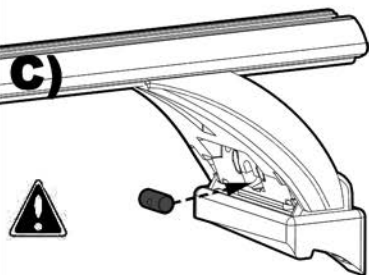
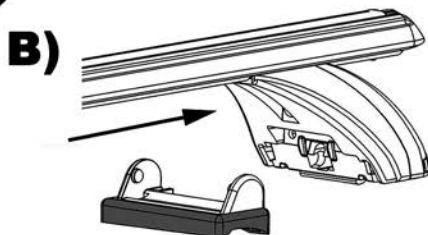
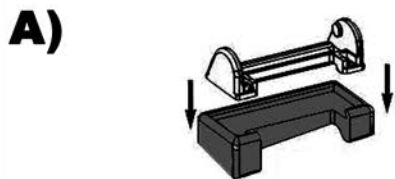

**6**

**x2**

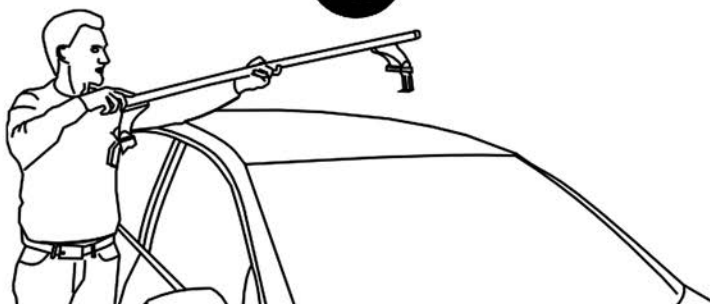

7

x4

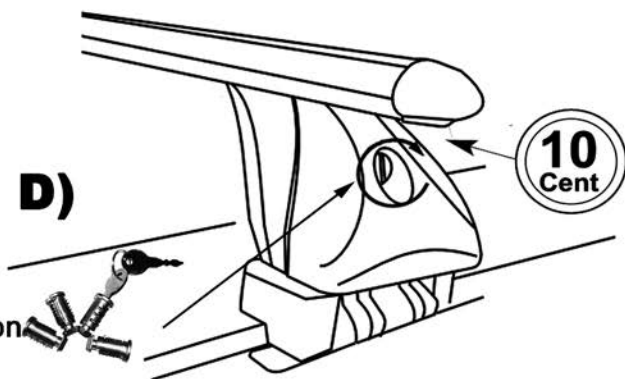
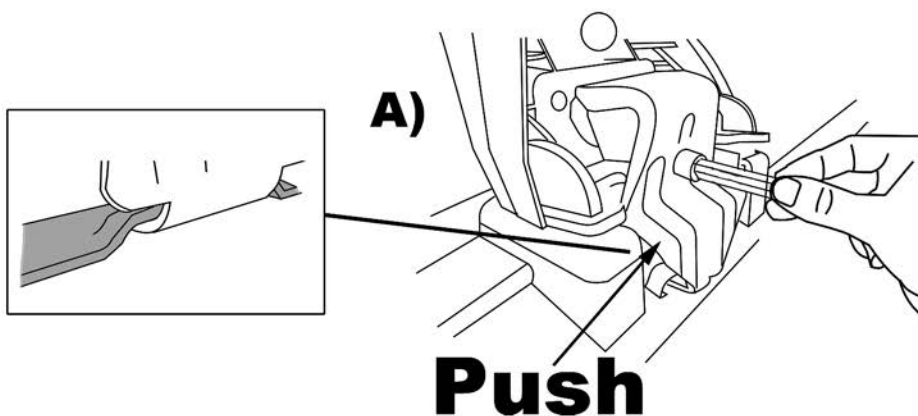
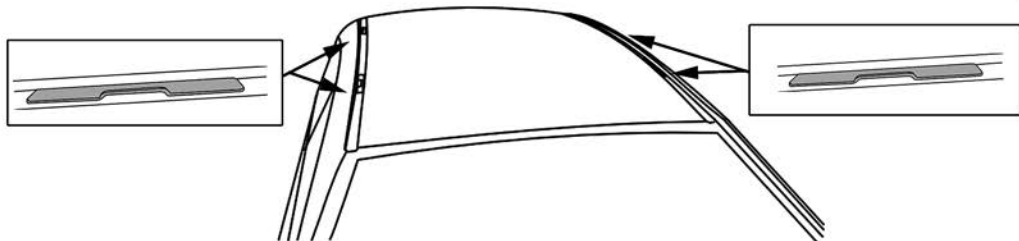

156.002 Option

**F** Serrer alternativement chaque côté  
**E** Alternare il serraggio delle viti  
**I** Serrare alternativamente  
**P** Aperte alternadamente  
**GB** Tighten alternately  
**D** Die Schrauben abwechselnd anziehen

**NL** Afwisselend aan de linker en de rechterkant aandraaien  
**S** Dra åt växelvis  
**FIN** Kierrä vuorotellen  
**EST** Pinguldage vaheldumisi  
**LAT** Pievelciēt pamāsus  
**LIT** Uzsukinėkite pakaitomis  
**PL** Sruby dokrecaj naprzemiennie

**CZ** Pokretla bagaznika dokrecaj dokrecaj naprzemiennie  
**SK** Dotahujte striedavo  
**SLO** Privijajte izmenicno  
**HR** Naizmjenicno zategnite  
**HU** Egymástól függetlenül szorítandó  
**TR** Dönüsmüli sikin

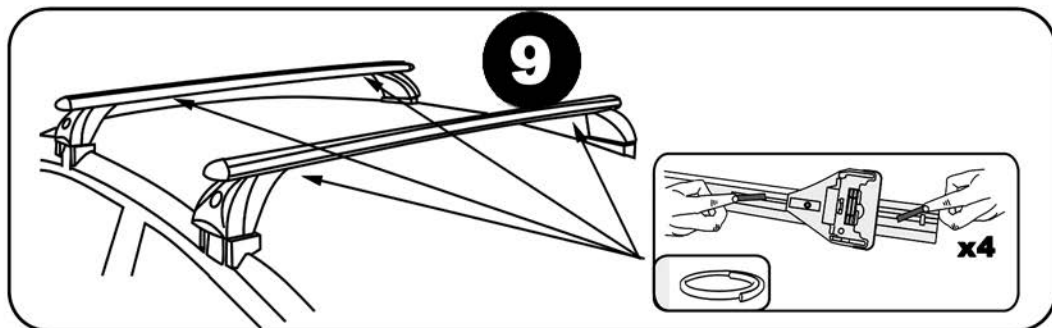
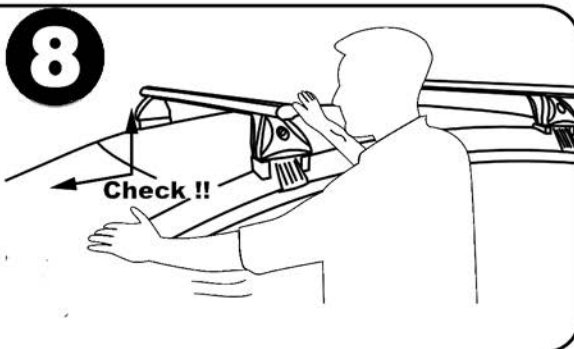

Démontage - Desmontaje - Smontaggio - Desmontagem - Disassembly - Demontage

